

Ilya and Emilia Kabakov

"Center of Cosmic Energy"

mike karstens graphics

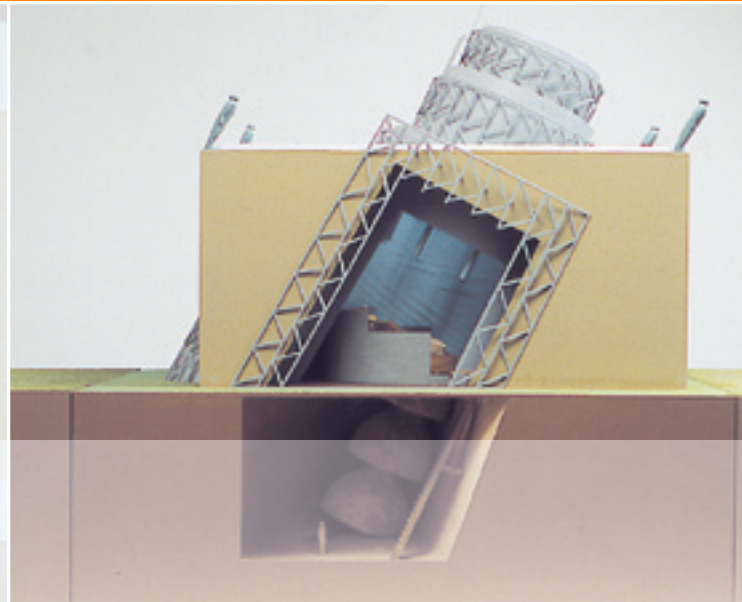

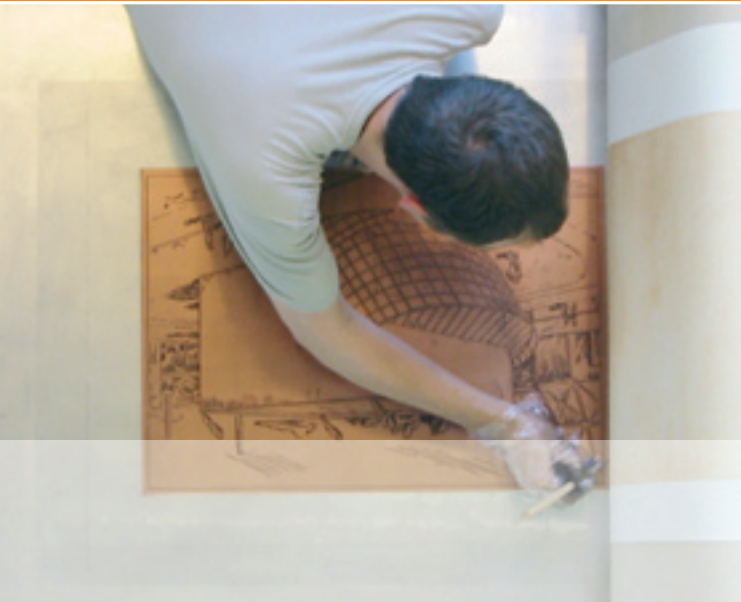
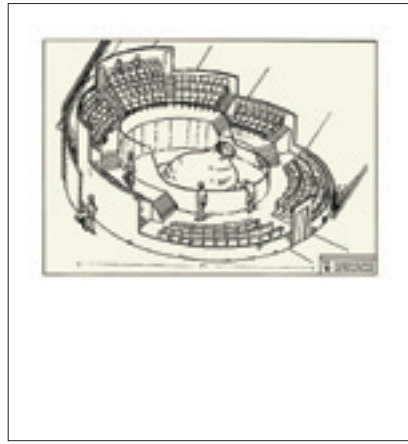
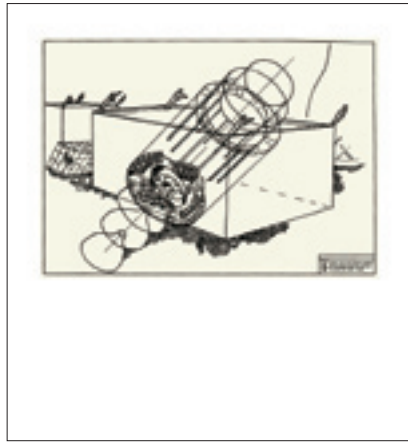
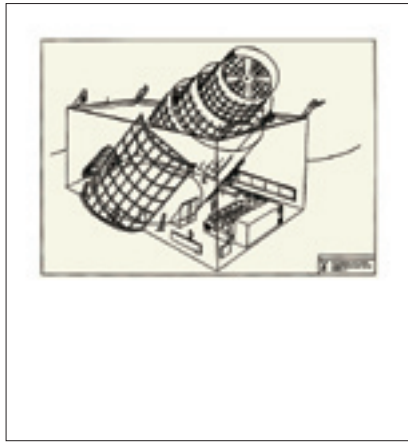
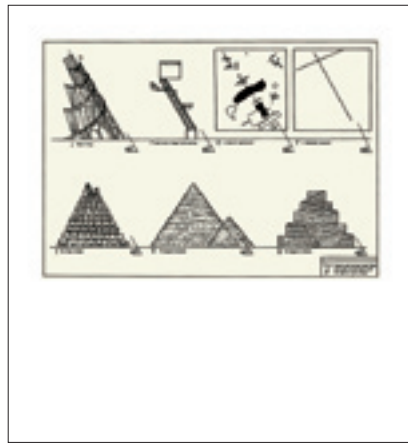
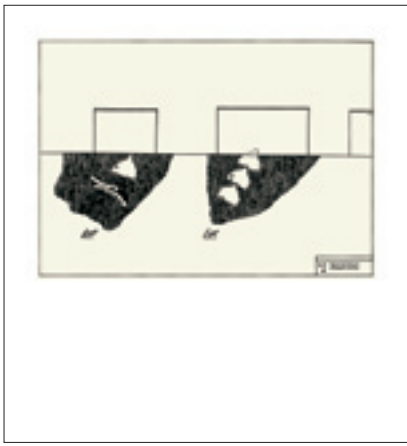
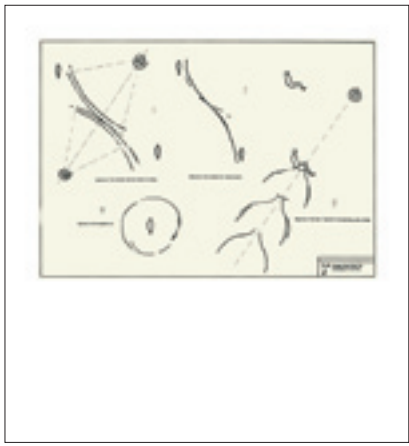

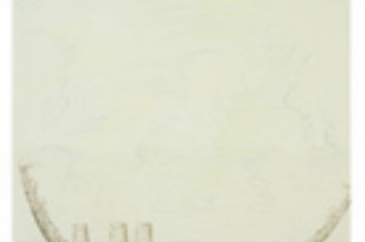
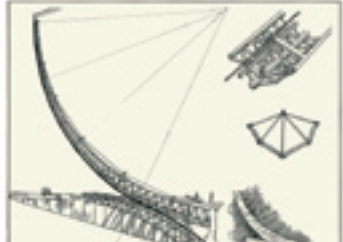
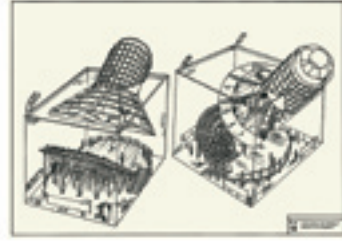
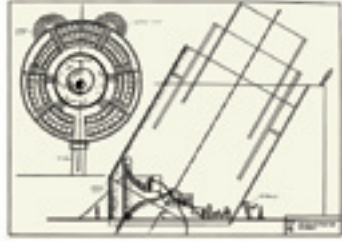

During archaeological digs on the property belonging to the Zollverein coke plant in Essen, Germany, two groups of objects were found, whose previous use is unknown. They are made of a condensed, very pure type of stone.

After deciding that the objects were of Celtic origin, the scientists' final hypothesis was that they were dealing with a „cosmic energy“ site. There are many of these sites all around the globe; churches and other religious buildings were often constructed on these sites.

People who come to such a place feel an increased sense of strength, stillness, and security. For this site, which has remained empty up until now, Ilya and Emilia Kabakov created the „Center of Cosmic Energy,“ a building complex where it will be possible to carry out a great experiment: the confirmation of the so-called Rosenfeld theory, which describes the ability of time to move backwards, or Wernadski's theory of the noosphere – a sphere surrounding the globe, where all of the intellectual activity of humanity throughout history is gathered.

In the portfolio here, the artists present the historical and archaeological assumptions, the various kinds of intuition, the two theories mentioned above, and an overview of the plans for the entire structure.

title, year
"Center of Cosmic Energy"
2003
technique
etching from two plates
edition
30/30, 10 a.p., 4 p.p.
paper
300 g/qm Hahnemühle
size
72 x 78 cm
printer
mike karstens graphics

Portfolio with 25 etchings,
inclusive one print handcoloured.
5 sheets with german/english
introduction.

mike karstens graphics

hafenweg 28, speicher II
48155 münster
germany

fon +49(0)251/6068780
fax +49(0)251/6098444
info@mikekarstensgraphics.com
www.mikekarstensgraphics.com

